

TC20

series



Product Segments

- **Care Motion**
- **Industrial Motion**

TC20 is an economical control box for a patient hoist system which meets specific patient needs and to secure a safe and comfortable transfer. It's portable and easy to be installed for the caregivers in the nursing home applications.

General Features

Number of actuators	1~3
Input voltage	100~240V AC
Built-in battery pack	24V, 2.9Ah / 5Ah
IP rating	Up to IP66
Options	MCU, battery LED indicator, cable management bracket

Emergency stop button
Easy installation

Drawing

Standard Dimensions
(mm)

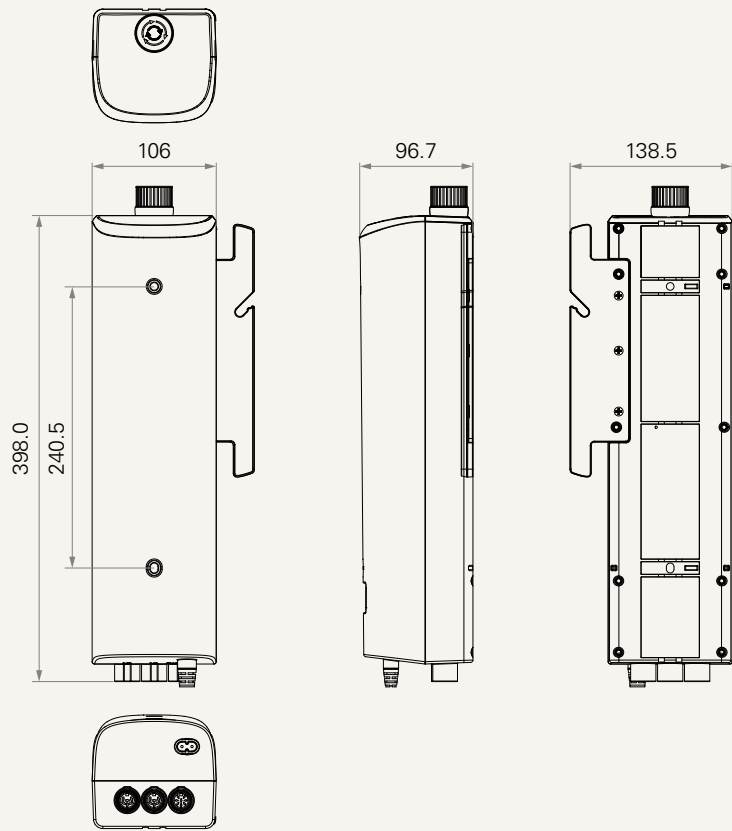

Input Voltage	4 = 100~240V AC		
MCU	0 = Without	1 = With	
Numbers of Actuators	1 = 1	2 = 2	3 = 3 (Using TYC to extend M2 socket for M2 actuator and M3 actuator)
Number of Controls	1 = 1		
Battery LED Indicator	0 = Without	1 = With	2 = With, for MCU #0
Battery Capacity	1 = 24V / 2.9Ah	2 = 24V / 5.0Ah	
Grounding	0 = Without		
AC Plug	1 = EU 2 = US	3 = AU 4 = UK	5 = JP
AC Plug Angle	2 = 180°		
AC Cable Length (mm)	0 = Without	1 = Straight, 1000	2 = Straight, 2000 3 = Straight, 3000
Color	3 = Cover Cool Gray 1C, Base Cool Gray 5C		
Cable Organizer	0 = Without	1 = With	
IP Rating	1 = Without	2 = IP54	3 = IP66

Terms of Use

The user is responsible for determining the suitability of TiMOTION products for a specific application. TiMOTION products are subject to change without prior notice.